

Self-serve lens display security.



- › A self-serve lens security solution designed for different sized camera lenses
- › Gives customers the ability to try a variety of DSLR camera lenses without store staff assistance
- › Reduces the usual theft concerns related to high value lenses on display
- › Part of InVue's IR Ecosystem™



FEATURES AND BENEFITS

- 1 Single lens security solution for different sized camera lenses
- 2 Enables customers to try a variety of lenses without assistance from store staff
- 3 Designed to work with S2800 or Zips 2.0 Alarm Units
- 4 'Gold is Good' LED indicates system status
- 5 Quick release capability with IR Key Fob for daily removal (not shown)
- 6 Optional lens stand available



IR ECOSYSTEM™

The LS100 is part of the exclusive InVue IR Ecosystem™, a storewide single key solution that improves customer service, increases sales and provides high theft protection.



- Handheld Electronics
- Electronic Accessories
- Secure Fixtures
- Package Protection
- Locked Cabinets
- Commercial Solutions



SPECIFICATIONS

LS100 Single Sensor (DNER50W/B):

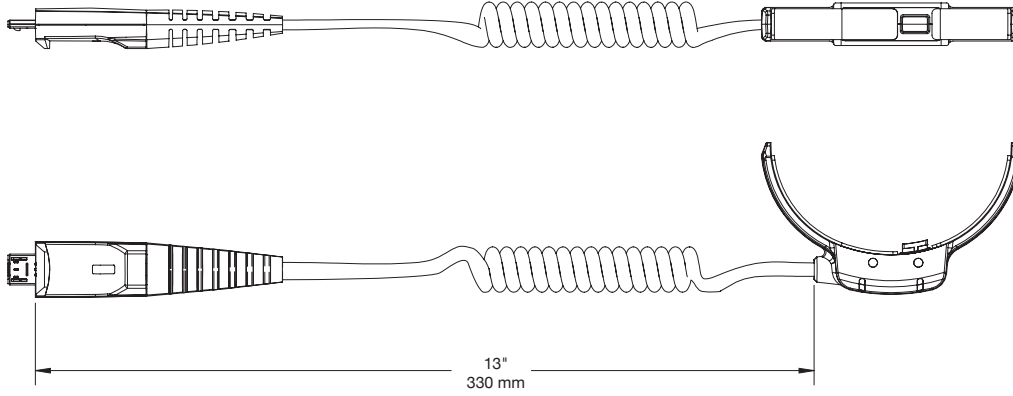

LS100 Single Stand (DNES50W/B):

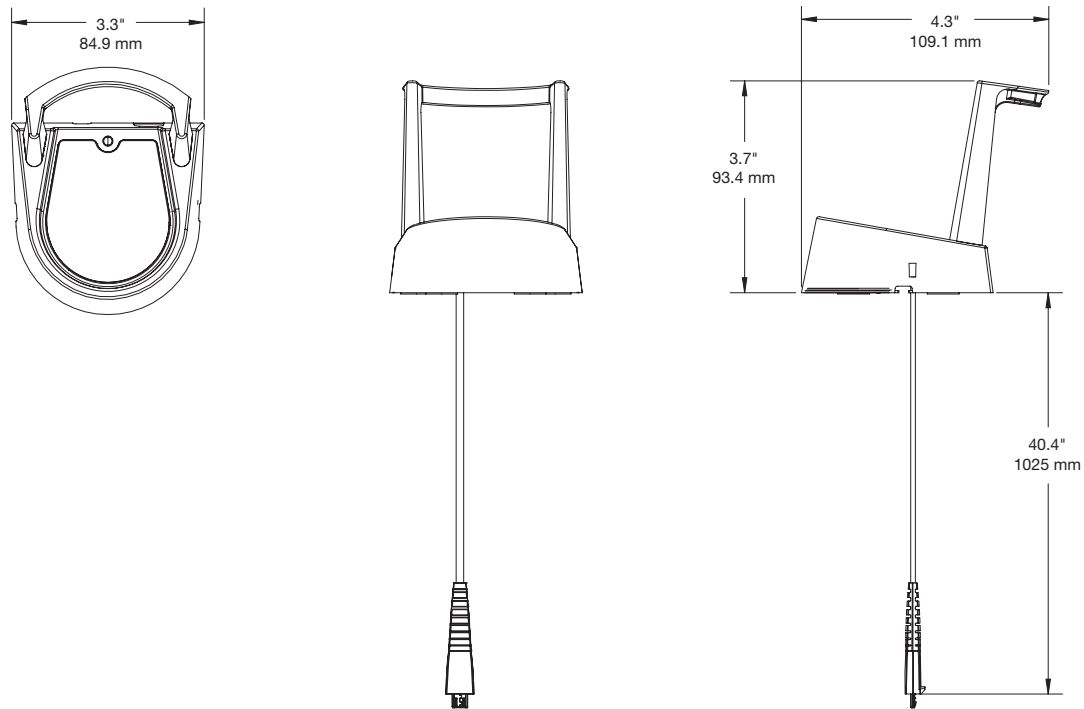

PRODUCT ORDERING

ORDER CODE	DESCRIPTION	CARTON QTY.
DNER50W DNER50B	LS100 Single Sensor - White LS100 Single Sensor - Black	32
DNES50W DNES50B	LS100 Single Stand - White LS100 Single Stand - Black	32
ADH2049	S2800 Lens Base Adhesive, 20 pack	20
ADH2048	S2800 Lens Sensor Adhesive, 8 pack	20

invue.com

©2016 InVue Security Products. No endorsement of InVue products has been made by any of the manufacturers of the products shown. Product is sold pursuant to InVue's warranty which can be found at www.invue.com/warranty.

THE AMERICAS 704.752.6513 • 888.55.INVUE

EUROPE, MIDDLE EAST & AFRICA +31.23.8900150

ASIA PACIFIC +852.3127.6811

