

Display, security, and quick access to power for today's cameras.

Fast. Secure. Economical.



Zips Camera is unique since it provides access to the camera battery chamber and OEM battery by unlocking the metallic shuttle on the sensor. The OEM camera battery is also electronically

secured once the metal shuttle is locked back into the sensor. This way, the OEM battery can securely be used to power the camera on display for weeks at a time between charging.



Zips Camera

PERFECTLY DISPLAYS POINT-AND-SHOOT AND DSLR CAMERAS

- 1 Adjustable mount ensures merchandise is easily centered
- 2 Adjustable stand supports large DSLR lenses
- 3 Available with lens sensor for DSLR cameras
- 4 Flashing red LED indicates system is providing alarming protection



Zips Camera

EXTREMELY EASY TO USE

- 1 Locking shuttle provides access to OEM battery for bi-weekly charging and secures the battery while on display
- 2 IR interface is always accessible
- 3 Sensor cable designed for daily removal



ALLOWS GREAT CUSTOMER INTERACTION

- 4 "Open Air" cable allows full interaction with the merchandise
- 5 Magnetic seat ensures camera will be left in perfect orientation



IR ECOSYSTEM™

Zips Camera is part of the exclusive InVue IR Ecosystem™, a storewide single key solution that improves customer service, increases sales and provides high theft protection.



Handheld Electronics

Electronic Accessories

Secure Fixtures

Package Protection

Locked Cabinets

Commercial Solutions



SPECIFICATIONS

Zips Camera Alarm Unit (ZA2002):

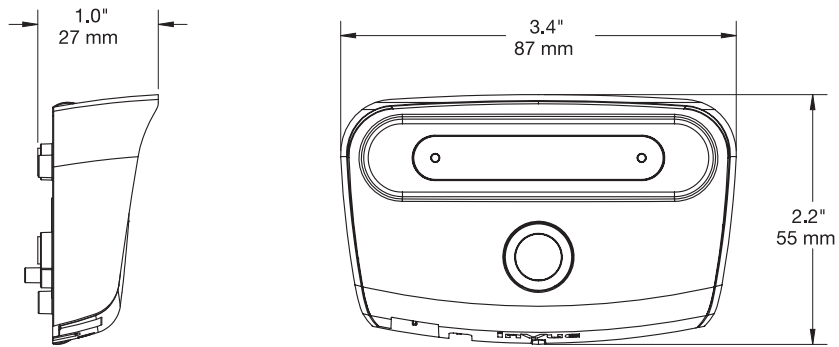

Zips Camera Lens Support Stand (ZA2500):

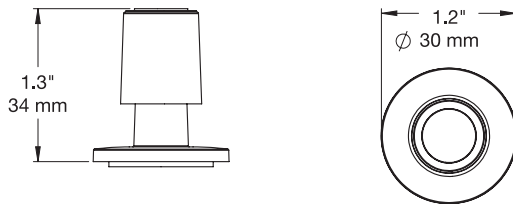

Zips Camera Sensor (ZA2300):

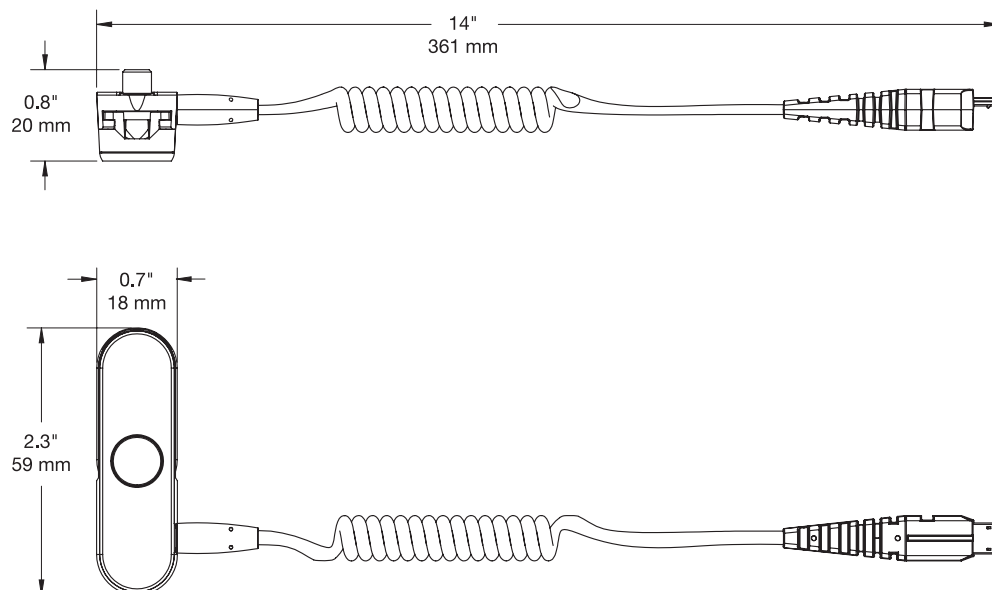

SPECIFICATIONS

Zips Camera with Lens Sensor (ZA2301):

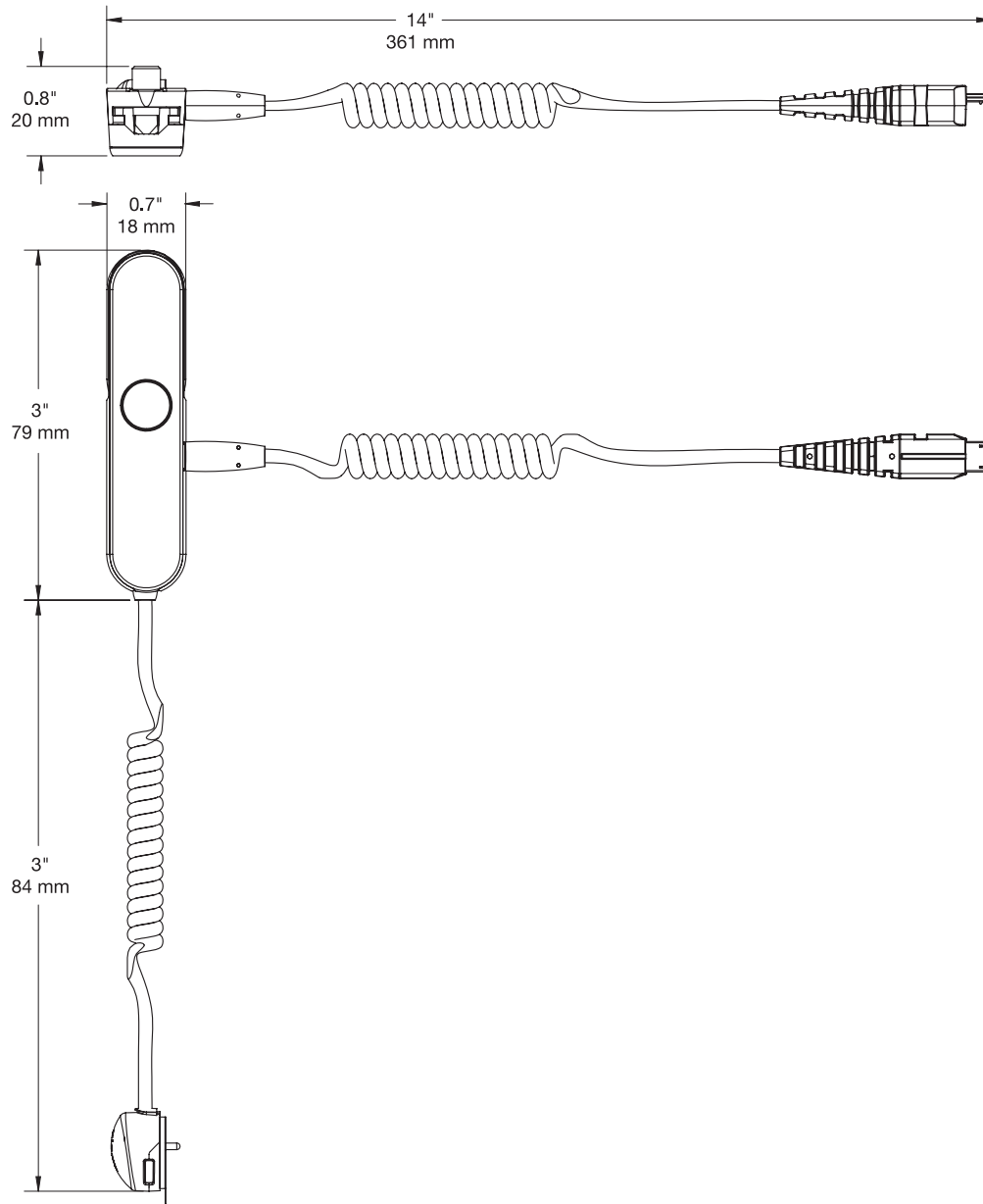

PRODUCT ORDERING

ORDER CODE	DESCRIPTION	CARTON QTY.
ZA2002-W ZA2002-B	Zips Camera Alarm Unit - White Zips Camera Alarm Unit - Black	1
ZA2300-W ZA2300-B	Zips Camera Sensor - White Zips Camera Sensor - Black	1
ZA2301-W ZA2301-B	Zips Camera with Lens Sensor - White Zips Camera with Lens Sensor - Black	1
ZA2500-W ZA2500-B	Zips Camera Lens Support Stand - White Zips Camera Lens Support Stand - Black	1
ADH2016	Zips Camera Alarm Unit Replacement Adhesive	20
ADH2026	Zips Camera Sensor Replacement Adhesive	20
ADH2033	Zips PSA Accessory Kit, Remote Adapter	20

invue.com

©2016 InVue Security Products. No endorsement of InVue products has been made by any of the manufacturers of the products shown. Product is sold pursuant to InVue's warranty which can be found at www.invue.com/warranty.

THE AMERICAS 704.752.6513 • 888.55.INVUE

EUROPE, MIDDLE EAST & AFRICA +31.23.8900150

ASIA PACIFIC +852.3127.6811