

Know what's on display.
Gain customer insight.
No matter where you are.



InVue InsightSM is an enterprise retail analytics solution that helps provide visibility to in-store activity of your smartphones and tablets on display. With an intelligent, networked POD you

can track planogram compliance, customer interaction (how many lifts and for how long) and security status — all through a cloud-based portal.



INSIGHT SYSTEM OVERVIEW

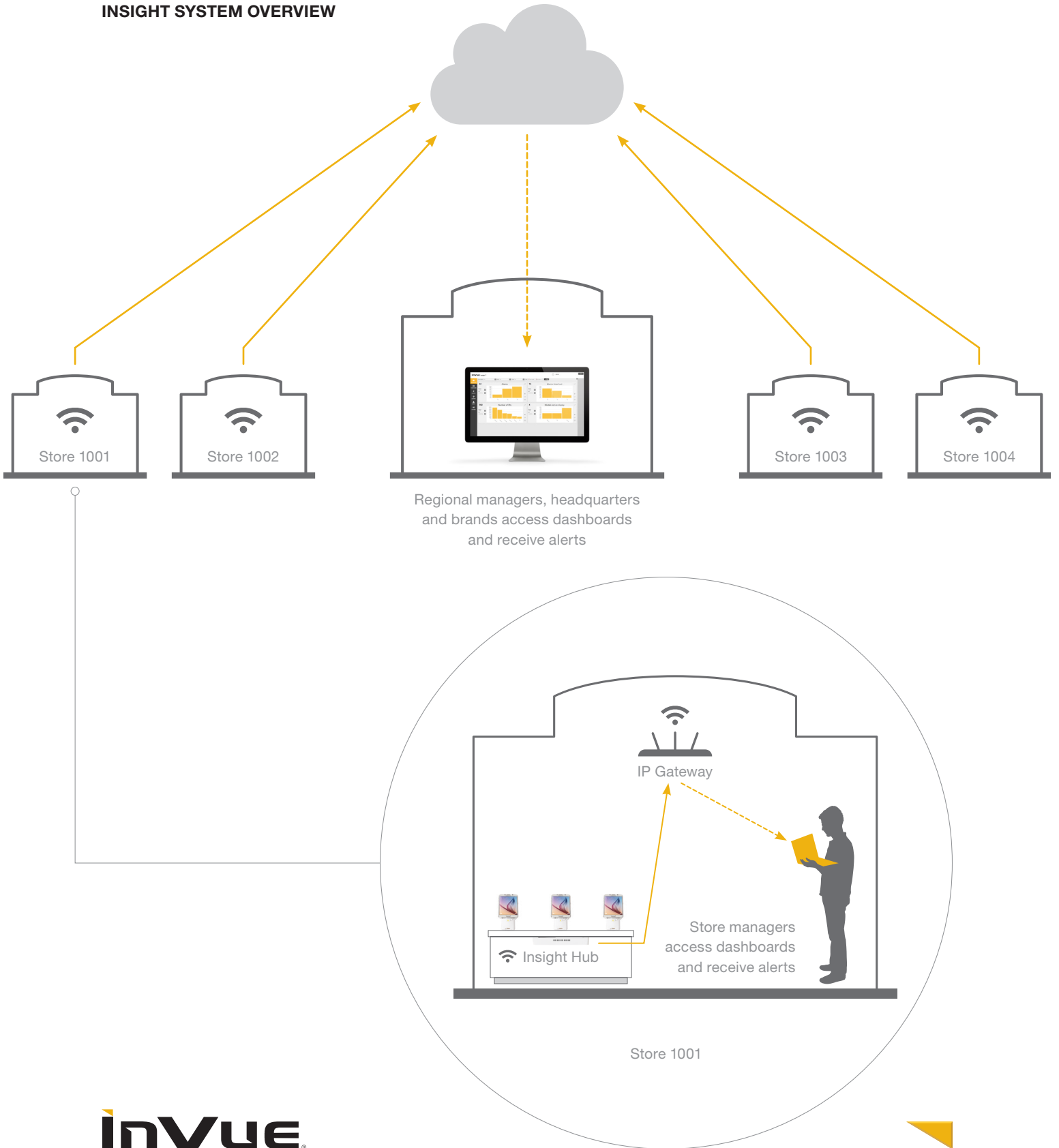

INSIGHT SYSTEM ANALYTICS EXAMPLES

With an intelligent, networked POD we provide the following through a cloud-based portal:

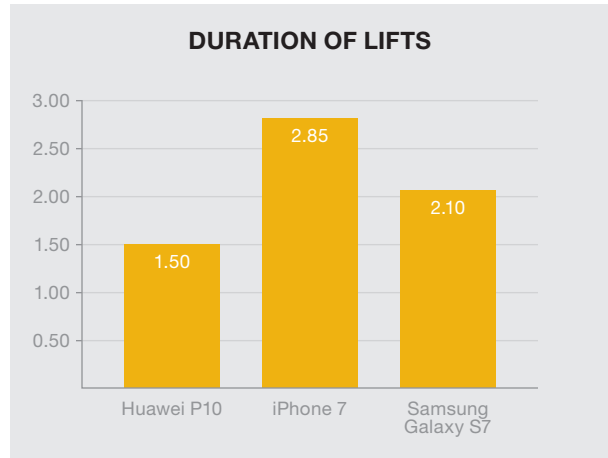
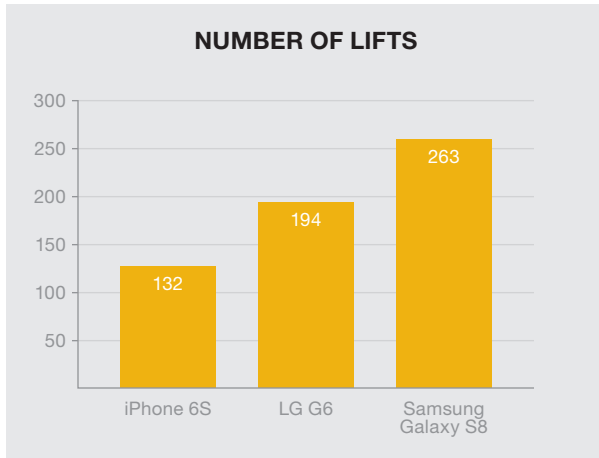

› *Activity:* Lifts, lift duration, and average lifts per store hour

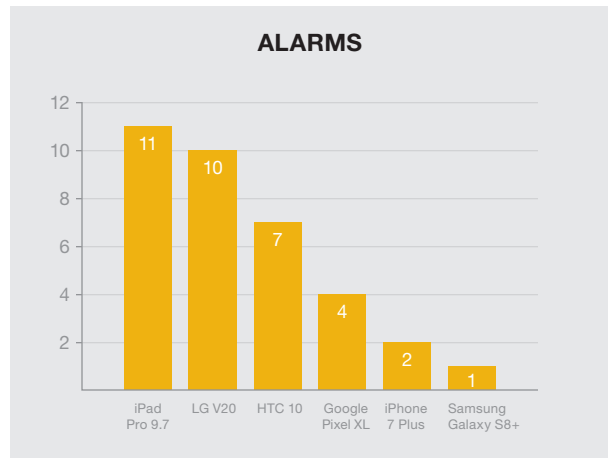
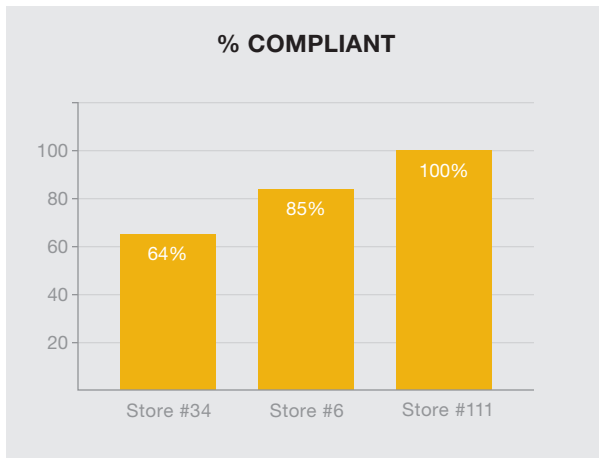

› *Planogram:* Type of device (e.g., brand and model) on each POD and missing devices

› *Security:* Alarms, alarms per hour, and alarms that timed out

This information can be easily accessed at the device, store, and enterprise level.



INSIGHT SYSTEM MONITORING

Notifications:

- › An alarm threshold at a defined location or region has been met
- › An alarm timed out after 2 minutes because store associates did not immediately address it with an IR key
- › A certain number of lifts have occurred in a specific time period

Communication method:

- › Configured for text or email
- › Customizable

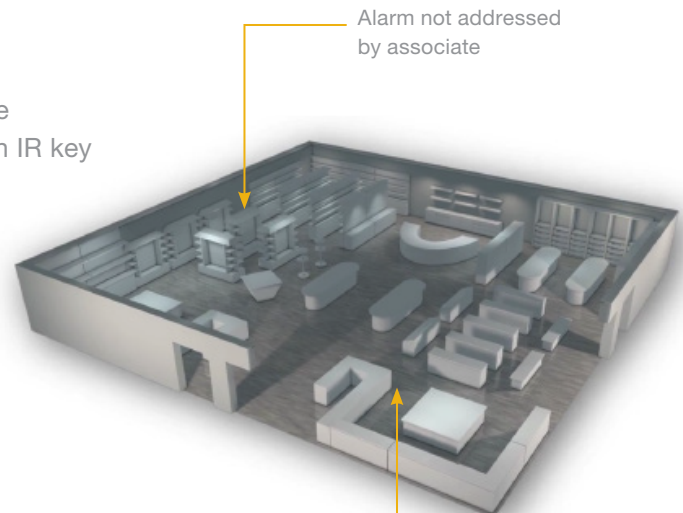

Store experiencing more device interactions than usual



SPECIFICATIONS

Insight Hub (INS1000-W):

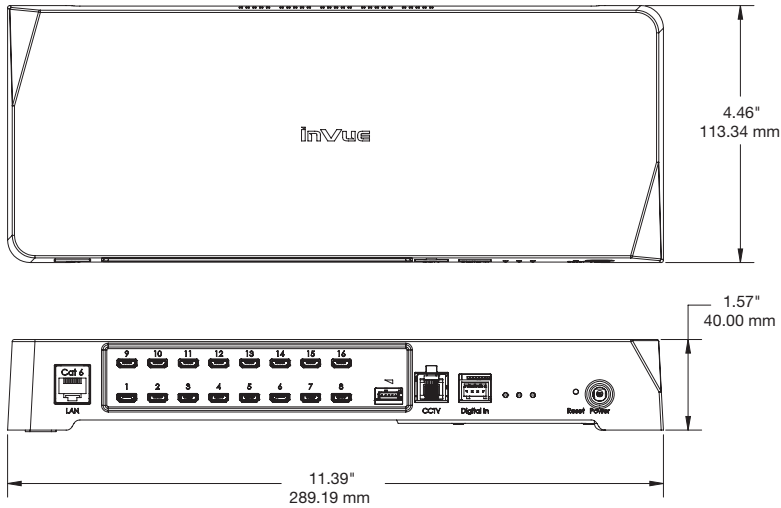

Insight Expansion Box (INS2000-W):

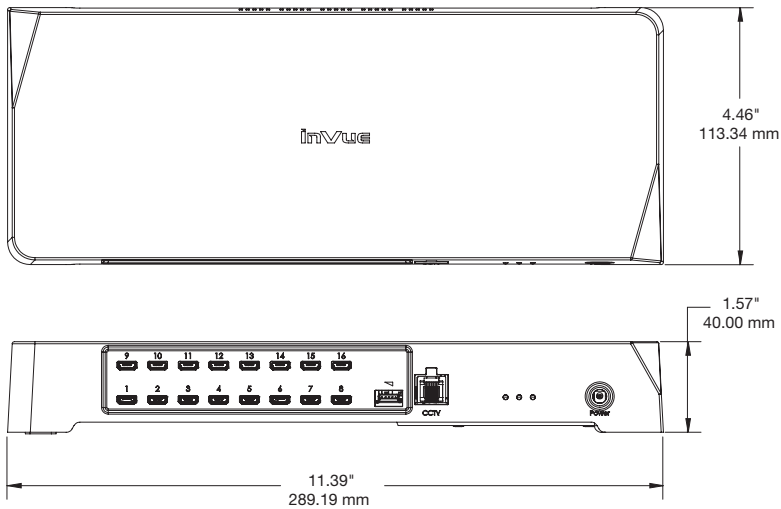

SPECIFICATIONS

5M Insight Expansion Box/Hub Data Cable (INS3100-W):

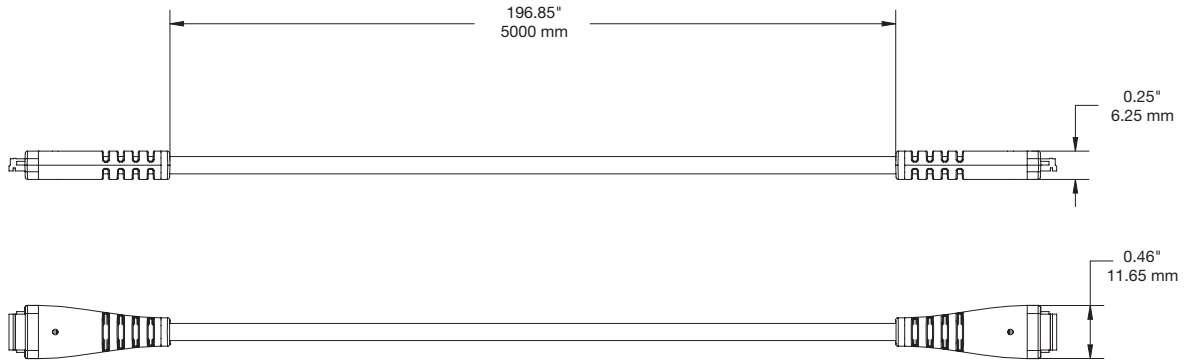

SPECIFICATIONS

5M Insight Hub/POD Data Cable Over Counter (INS3210-W):

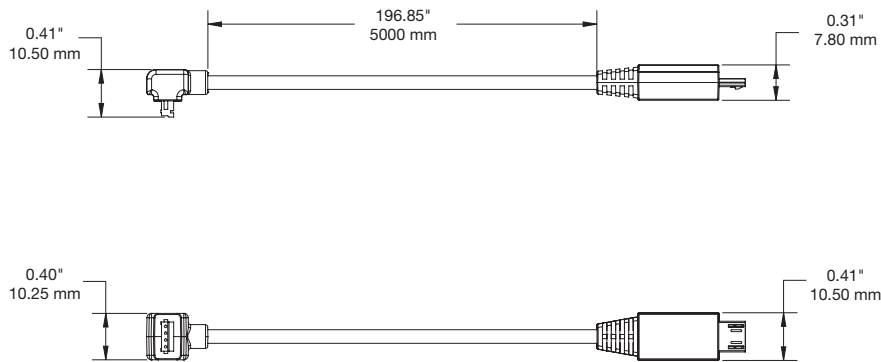

SPECIFICATIONS

2.5M Insight Hub/POD Data Cable Over Counter (INS3310-W):

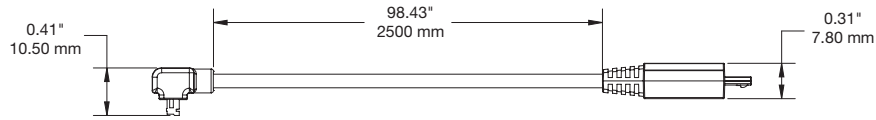

Series 1060 Flat Stand (DRD105-W):

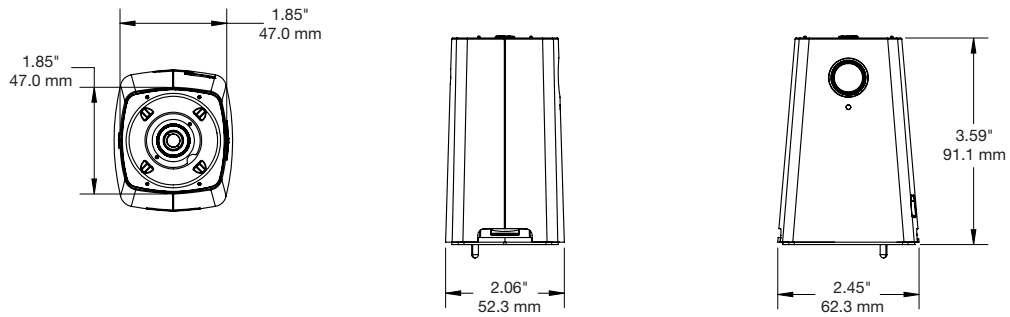

SPECIFICATIONS

Series 1060 Angled Stand (DRD106-W):

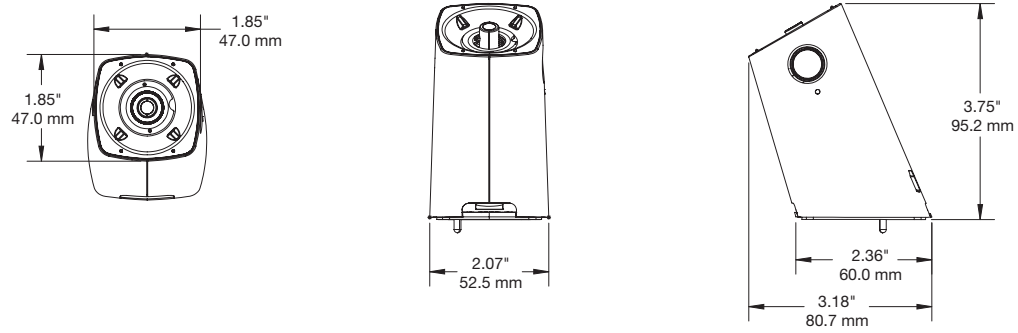

Series 1560 Angled Alarming Stand (DSD100-W):

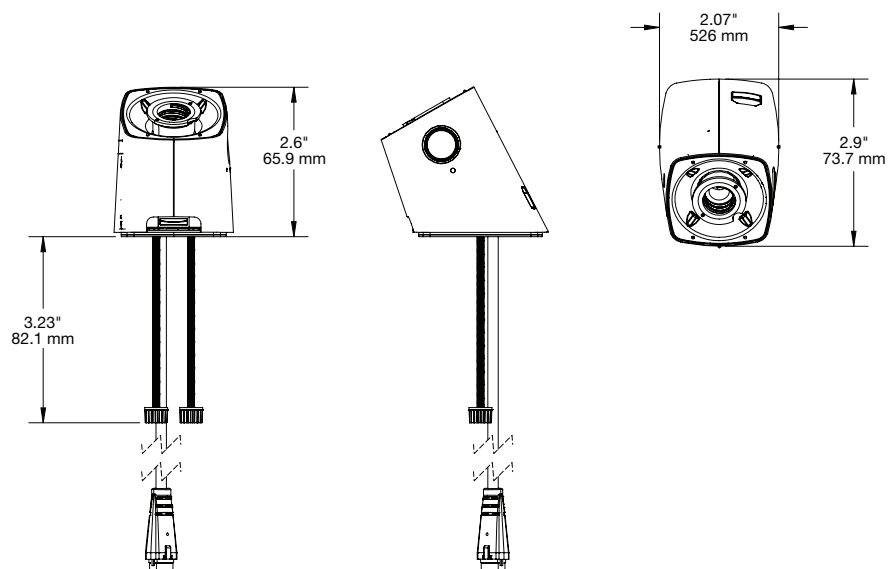

SPECIFICATIONS

Series 1560 Zero Degree Alarming Stand (DSD101-W):

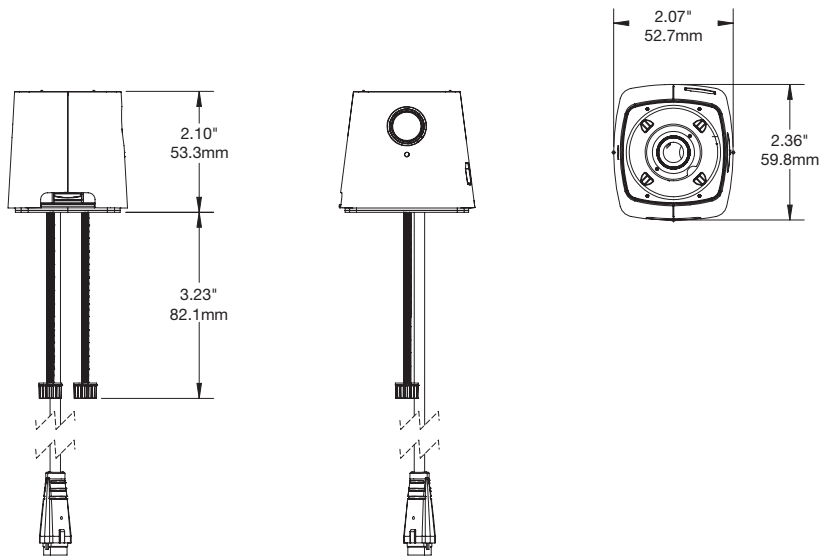

Series 1560 Recoiler (DSD300-W):

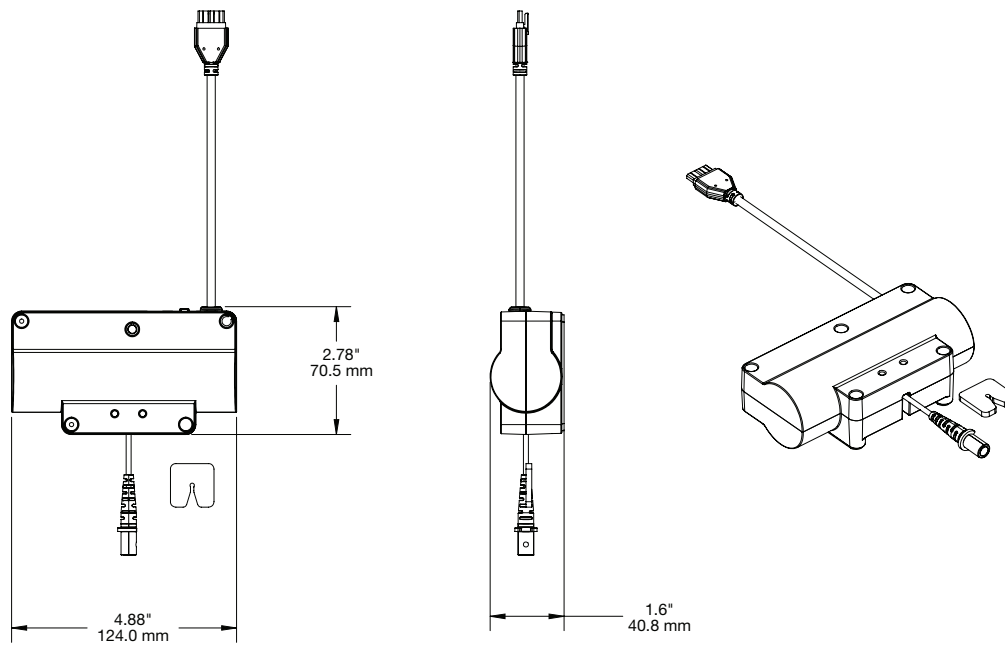

PRODUCT ORDERING

ORDER CODE	DESCRIPTION	NOTES
HUBS, EXPANSION BOXES, AND POWER SUPPLIES		
INS1000-W	Insight Hub - White	
INS2000-W	Insight Expansion Box - White	
INS4000-B	USB-A to Insight Power Connector - Black	› Required to connect each INS1000 or INS2000 to a power supply
PS515-US PS515-UK PS515-JPN PS515-EU PS515-AUS	5V USB-A Positive Slope Power Supply - United States 5V USB-A Positive Slope Power Supply - United Kingdom 5V USB-A Positive Slope Power Supply - Japan 5V USB-A Positive Slope Power Supply - Europe 5V USB-A Positive Slope Power Supply - Australia	› For INS1000 or INS2000
CABLES		
INS3100-W	5M Insight Expansion/Hub Data Cable - White	
INS3210-W	5M Insight Hub/POD Data Cable - White	› Use for both over counter and through counter installations
INS3310-W	2.5M Insight Hub/POD Data Cable - White	› Use for both over counter and through counter installations
INSIGHT STANDS AND POWER SUPPLIES		
DRD105-W	Series 1060 Flat Stand - White	
DRD106-W	Series 1060 Angled Stand - White	
DSD100-W	Series 1560 Angled Alarming Stand - White	
DSD101-W	Series 1560 Zero Degree Alarming Stand - White	
DSD300-W	Series 1560 Recoiler - White	
PS531-US PS531-UK PS531-JPN PS531-EU PS531-AUS	5V 3A Power Supply - United States 5V 3A Power Supply - United Kingdom 5V 3A Power Supply - Japan 5V 3A Power Supply - Europe 5V 3A Power Supply - Australia	› For Insight stands



PRODUCT ORDERING

ORDER CODE	DESCRIPTION	NOTES
INSIGHT SENSORS		
DRH210-W	S1060/S1560 HH Micro USB Android Insight Sensor - White	› Needed for Insight Gold
DRH211-W	S1060/S1560 HH Apple Lightning Insight Sensor - White	› Needed for Insight Gold
DRH213-W	S1060/S1560 HH USB Type C Android Insight Sensor - Wht	› Needed for Insight Gold
DRT210-W	S1060/S1560 TAB Micro-USB Android Insight Sensor - Wht	› Needed for Insight Gold
DRT211-W	S1060/S1560 TAB Apple Lightning Insight Sensor - White	› Needed for Insight Gold
DRT213-W	S1060/S1560 TAB USB Type C Android Insight Sensor - Wht	› Needed for Insight Gold
SOFTWARE SUBSCRIPTION		
INS6100	Insight Monthly Pricing 1-99 devices	
INS6200	Insight Monthly Pricing 100-249 devices	
INS6300	Insight Monthly Pricing 250-499 devices	
INS6400	Insight Monthly Pricing 500-2,499 devices	
INS6500	Insight Monthly Pricing 2,500-4,999 devices	
INS6600	Insight Monthly Pricing 5,000-9,999 devices	
INS6700	Insight Monthly Pricing 10,000-24,999 devices	
INS6800	Insight Monthly Pricing 25,000-49,999 devices	
INS6900	Insight Monthly Pricing 50,000+ devices	
TRAINING AND SETUP SERVICES		
INS5000	Insight Partner Training	
INS8000	Insight Initial Setup Services	

invue.com

©2018 InVue Security Products. No endorsement of InVue products has been made by any of the manufacturers of the products shown. Product is sold pursuant to InVue's warranty which can be found at www.invue.com/warranty.

THE AMERICAS 704.752.6513 • 888.55.INVUE
EUROPE, MIDDLE EAST & AFRICA +31.23.8900150
ASIA PACIFIC +852.3127.6811

